

Finite State Machine for Control

- Implementation:

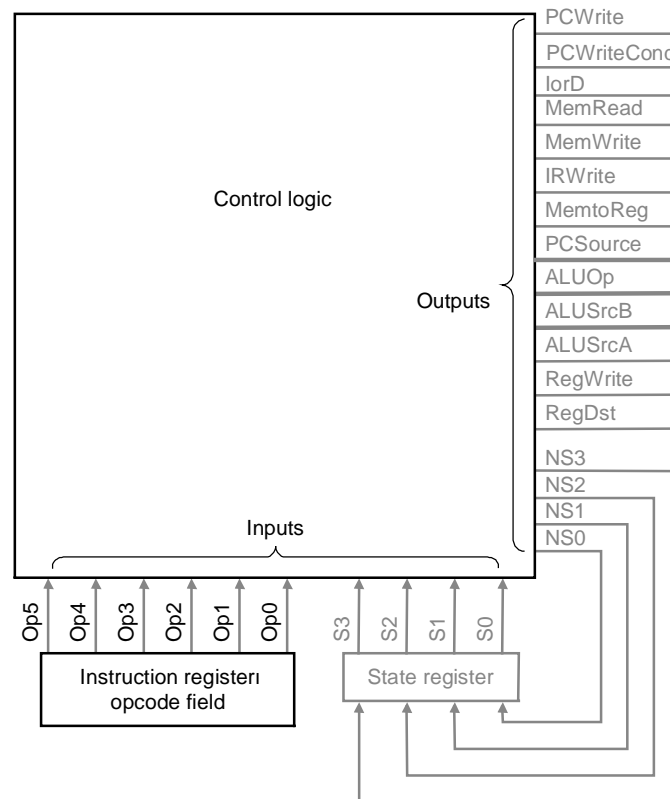

ROM Implementation

- ROM = "Read Only Memory"
 - values of memory locations are fixed ahead of time
- A ROM can be used to implement a truth table
 - if the address is m -bits, we can address 2^m entries in the ROM.
 - our outputs are the bits of data that the address points to.

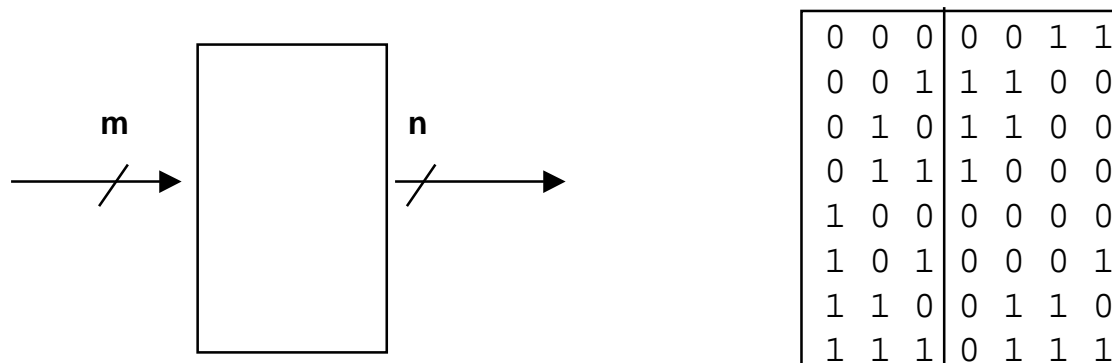

m is the "height", and n is the "width"

ROM Implementation

- **How many inputs are there?**
6 bits for opcode, 4 bits for state = 10 address lines
(i.e., $2^{10} = 1024$ different addresses)
- **How many outputs are there?**
16 datapath-control outputs, 4 state bits = 20 outputs
- **ROM is $2^{10} \times 20 = 20\text{K}$ bits (and a rather unusual size)**
- **Rather wasteful, since for lots of the entries, the outputs are the same**
— i.e., opcode is often ignored

PLA Implementation

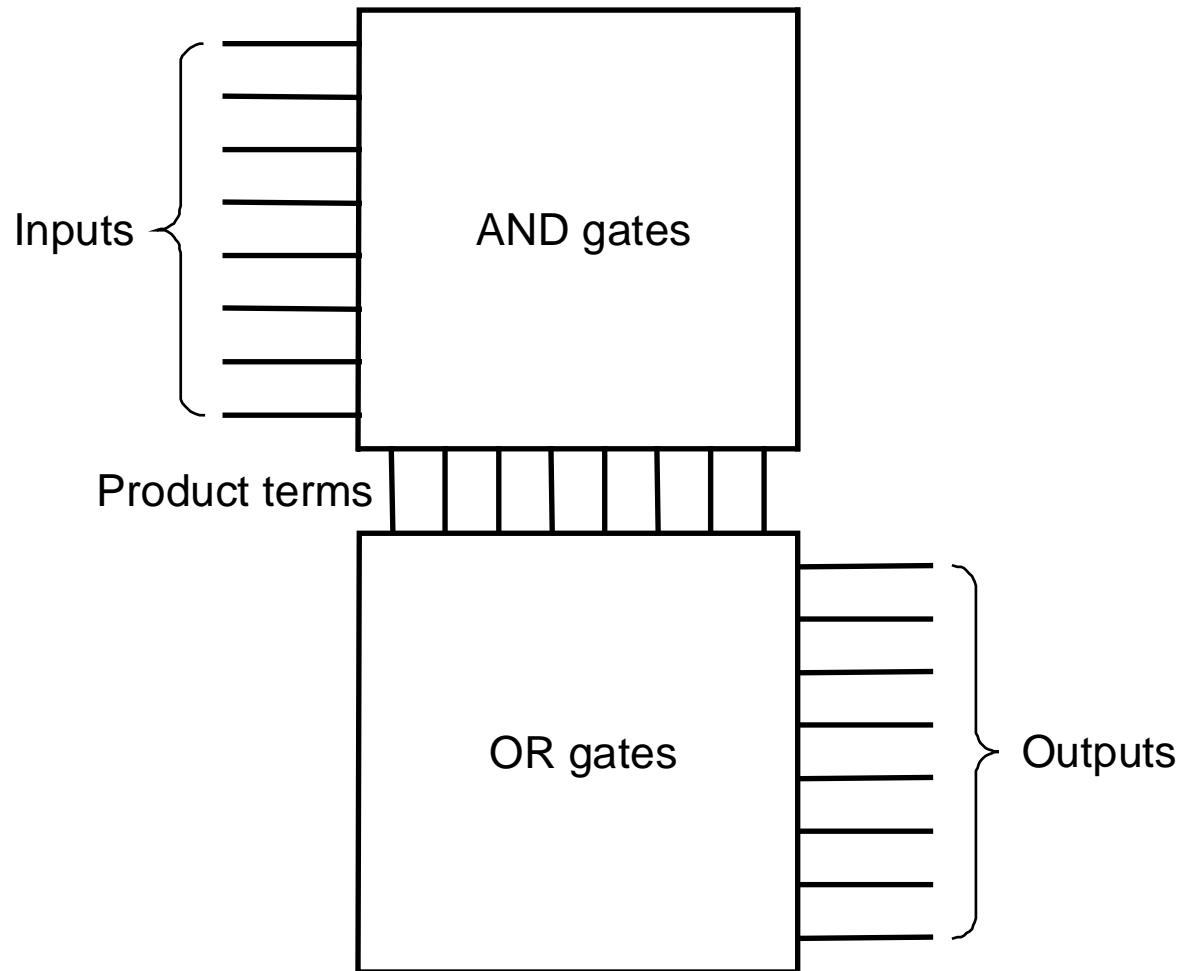

PLA Implementation

- If I picked a horizontal or vertical line could you explain it?

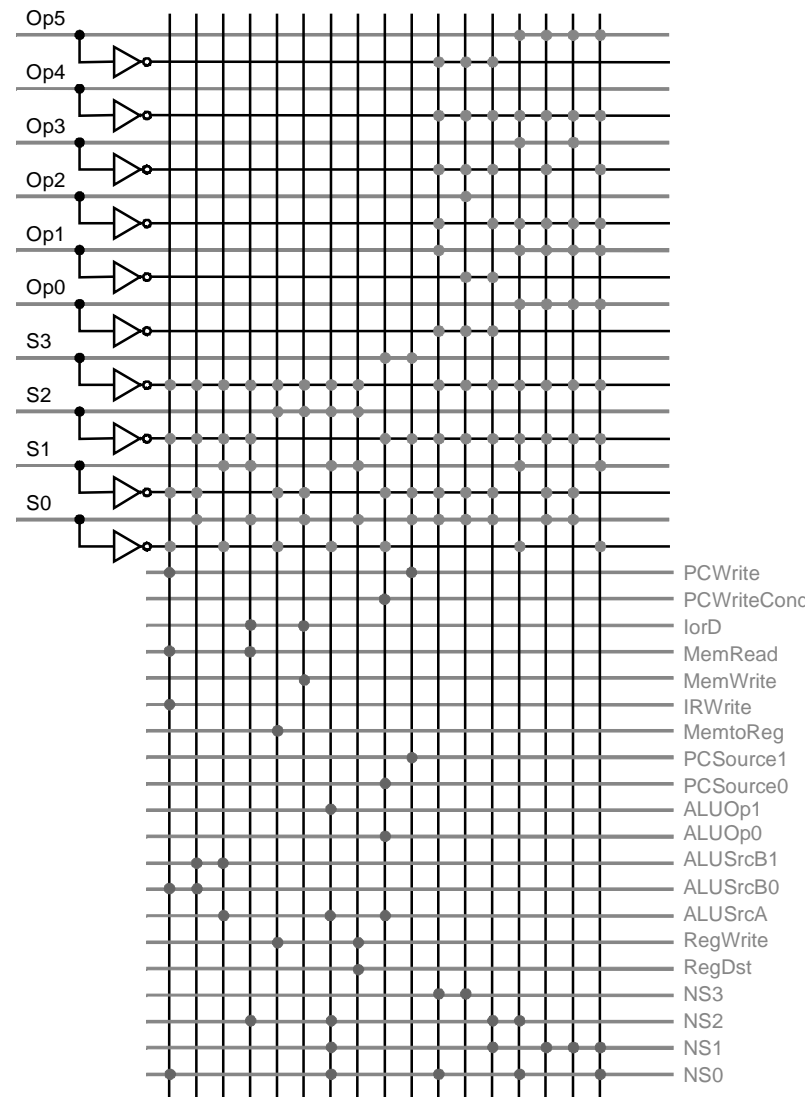

ROM vs PLA

- Break up the table into two parts
 - 4 state bits tell you the 16 outputs, $2^4 \times 16$ bits of ROM
 - 10 bits tell you the 4 next state bits, $2^{10} \times 4$ bits of ROM
 - Total: 4.3K bits of ROM
- PLA is much smaller
 - can share product terms
 - only need entries that produce an active output
 - can take into account don't cares
- Size is $(\#inputs \times \#product\text{-terms}) + (\#outputs \times \#product\text{-terms})$
For this example = $(10 \times 17) + (20 \times 17) = 460$ PLA cells
- PLA cells usually about the size of a ROM cell (slightly bigger)

Another Implementation Style

- **Complex instructions: the "next state" is often current state + 1**

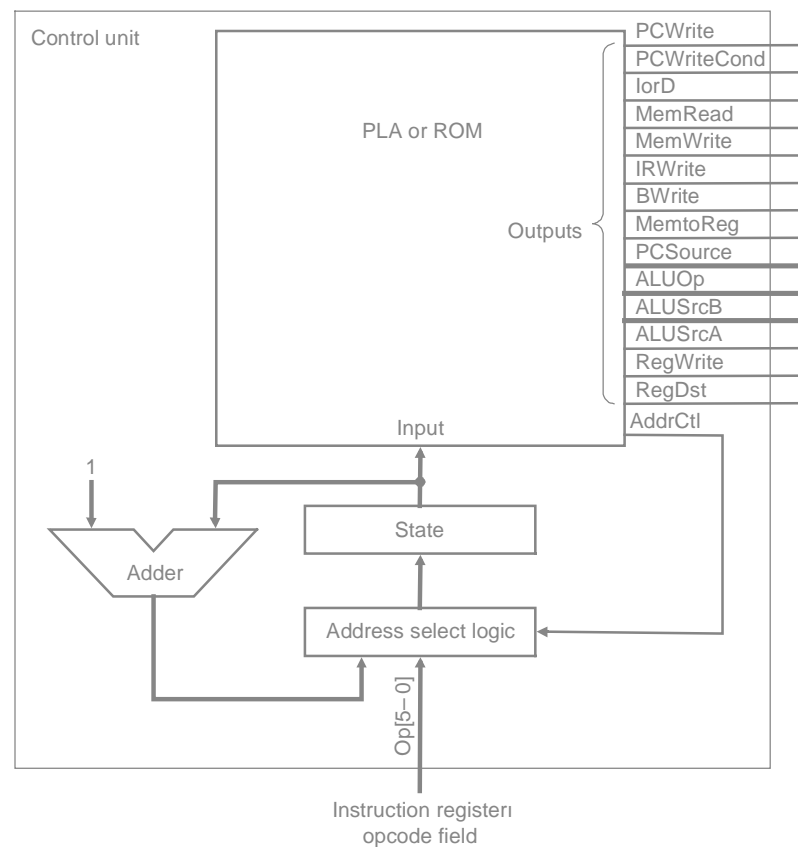

Details

Dispatch ROM 1		
Op	Opcode name	Value
000000	R-format	0110
000010	jmp	1001
000100	beq	1000
100011	lw	0010
101011	sw	0010

Dispatch ROM 2		
Op	Opcode name	Value
100011	lw	0011
101011	sw	0101

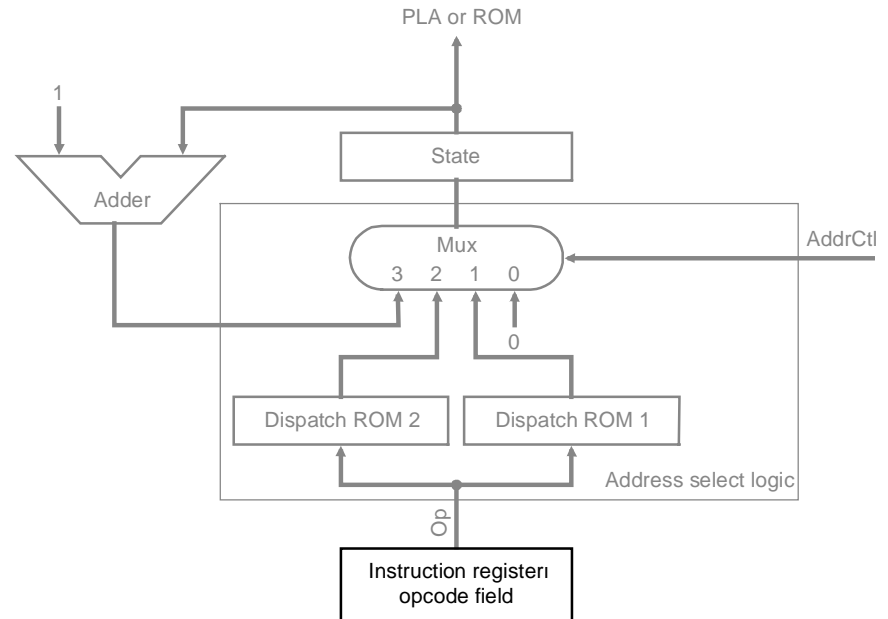

State number	Address-control action	Value of AddrCtl
0	Use incremented state	3
1	Use dispatch ROM 1	1
2	Use dispatch ROM 2	2
3	Use incremented state	3
4	Replace state number by 0	0
5	Replace state number by 0	0
6	Use incremented state	3
7	Replace state number by 0	0
8	Replace state number by 0	0
9	Replace state number by 0	0

Microprogramming

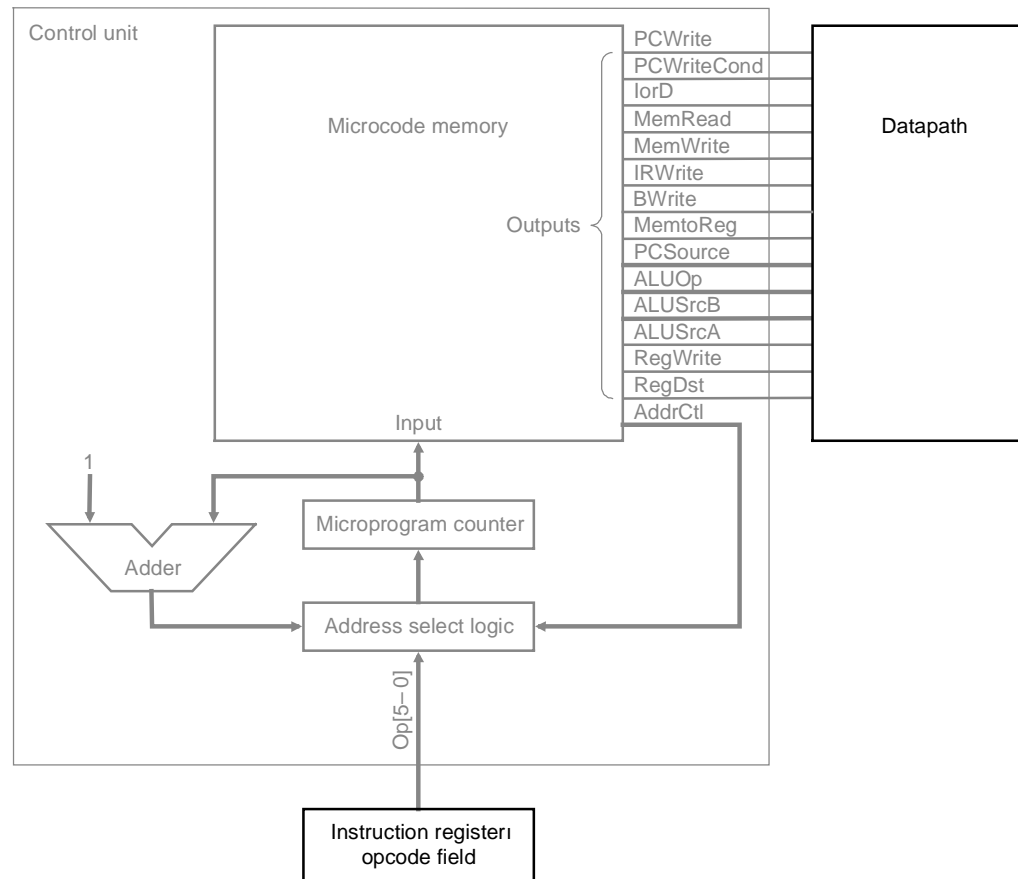

- What are the “microinstructions” ?

Microprogramming

- A specification methodology
 - appropriate if hundreds of opcodes, modes, cycles, etc.
 - signals specified symbolically using microinstructions

Label	ALU control	SRC1	SRC2	Register control	Memory	PCWrite control	Sequencing
Fetch	Add	PC	4		Read PC	ALU	Seq
	Add	PC	Extshft	Read			Dispatch 1
Mem1	Add	A	Extend				Dispatch 2
LW2					Read ALU		Seq
				Write MDR			Fetch
SW2					Write ALU		Fetch
Rformat1	Func code	A	B				Seq
				Write ALU			Fetch
BEQ1	Subt	A	B			ALUOut-cond	Fetch
JUMP1						Jump address	Fetch

- *Will two implementations of the same architecture have the same microcode?*
- *What would a microassembler do?*

Microinstruction format

Field name	Value	Signals active	Comment
ALU control	Add	ALUOp = 00	Cause the ALU to add.
	Subt	ALUOp = 01	Cause the ALU to subtract; this implements the compare for branches.
	Func code	ALUOp = 10	Use the instruction's function code to determine ALU control.
SRC1	PC	ALUSrcA = 0	Use the PC as the first ALU input.
	A	ALUSrcA = 1	Register A is the first ALU input.
SRC2	B	ALUSrcB = 00	Register B is the second ALU input.
	4	ALUSrcB = 01	Use 4 as the second ALU input.
	Extend	ALUSrcB = 10	Use output of the sign extension unit as the second ALU input.
	Extshft	ALUSrcB = 11	Use the output of the shift-by-two unit as the second ALU input.
Register control	Read		Read two registers using the rs and rt fields of the IR as the register numbers and putting the data into registers A and B.
	Write ALU	RegWrite, RegDst = 1, MemtoReg = 0	Write a register using the rd field of the IR as the register number and the contents of the ALUOut as the data.
	Write MDR	RegWrite, RegDst = 0, MemtoReg = 1	Write a register using the rt field of the IR as the register number and the contents of the MDR as the data.
Memory	Read PC	MemRead, lorD = 0	Read memory using the PC as address; write result into IR (and the MDR).
	Read ALU	MemRead, lorD = 1	Read memory using the ALUOut as address; write result into MDR.
	Write ALU	MemWrite, lorD = 1	Write memory using the ALUOut as address, contents of B as the data.
PC write control	ALU	PCSource = 00 PCWrite	Write the output of the ALU into the PC.
	ALUOut-cond	PCSource = 01, PCWriteCond	If the Zero output of the ALU is active, write the PC with the contents of the register ALUOut.
	jump address	PCSource = 10, PCWrite	Write the PC with the jump address from the instruction.
Sequencing	Seq	AddrCtl = 11	Choose the next microinstruction sequentially.
	Fetch	AddrCtl = 00	Go to the first microinstruction to begin a new instruction.
	Dispatch 1	AddrCtl = 01	Dispatch using the ROM 1.
	Dispatch 2	AddrCtl = 10	Dispatch using the ROM 2.

Microcode: Trade-offs

- **Distinction between specification and implementation is sometimes blurred**
- **Specification Advantages:**
 - **Easy to design and write**
 - **Design architecture and microcode in parallel**
- **Implementation (off-chip ROM) Advantages**
 - **Easy to change since values are in memory**
 - **Can emulate other architectures**
 - **Can make use of internal registers**
- **Implementation Disadvantages, SLOWER now that:**
 - **Control is implemented on same chip as processor**
 - **ROM is no longer faster than RAM**
 - **No need to go back and make changes**

Datapath implementing exceptions

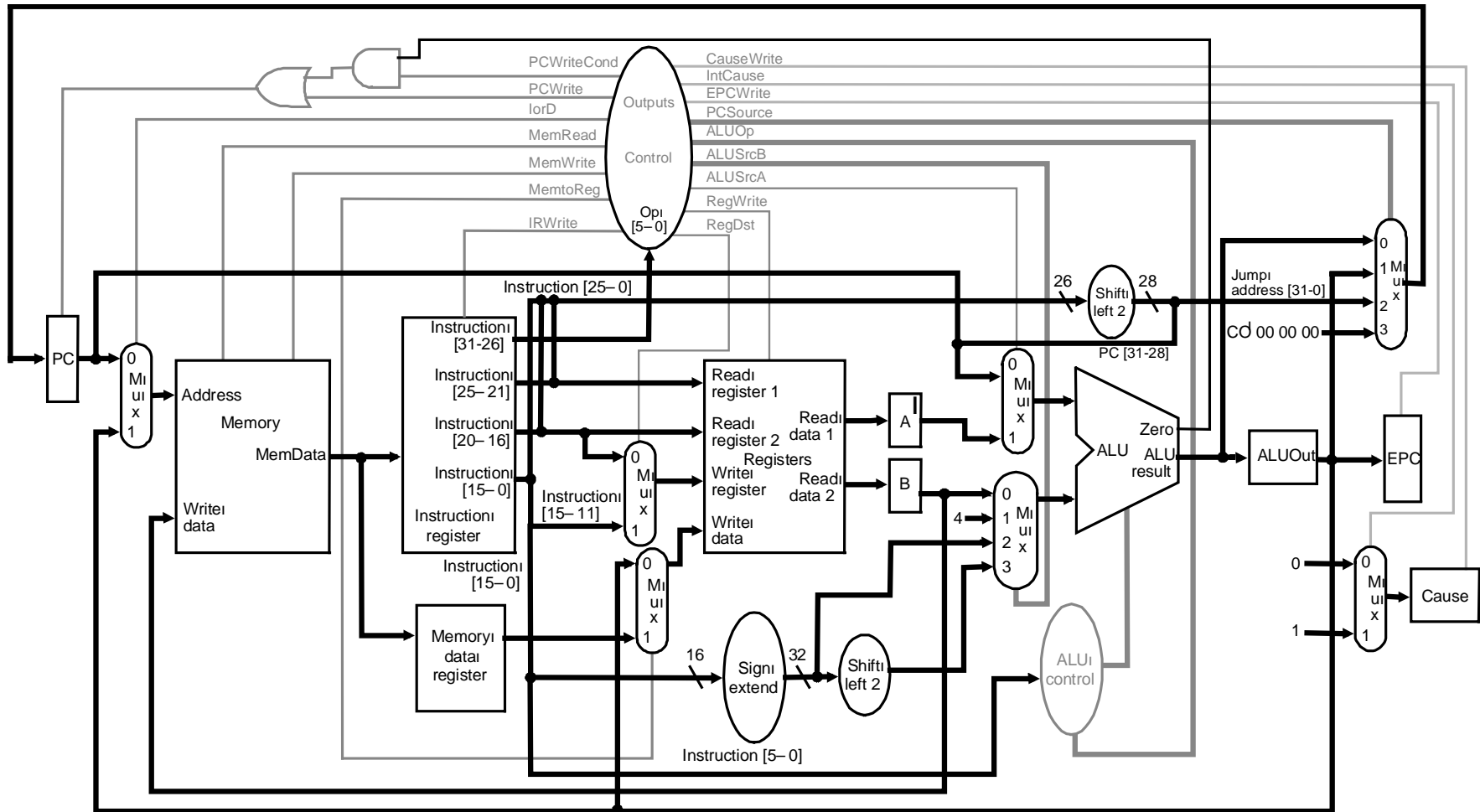

Finite state machine with exception handling

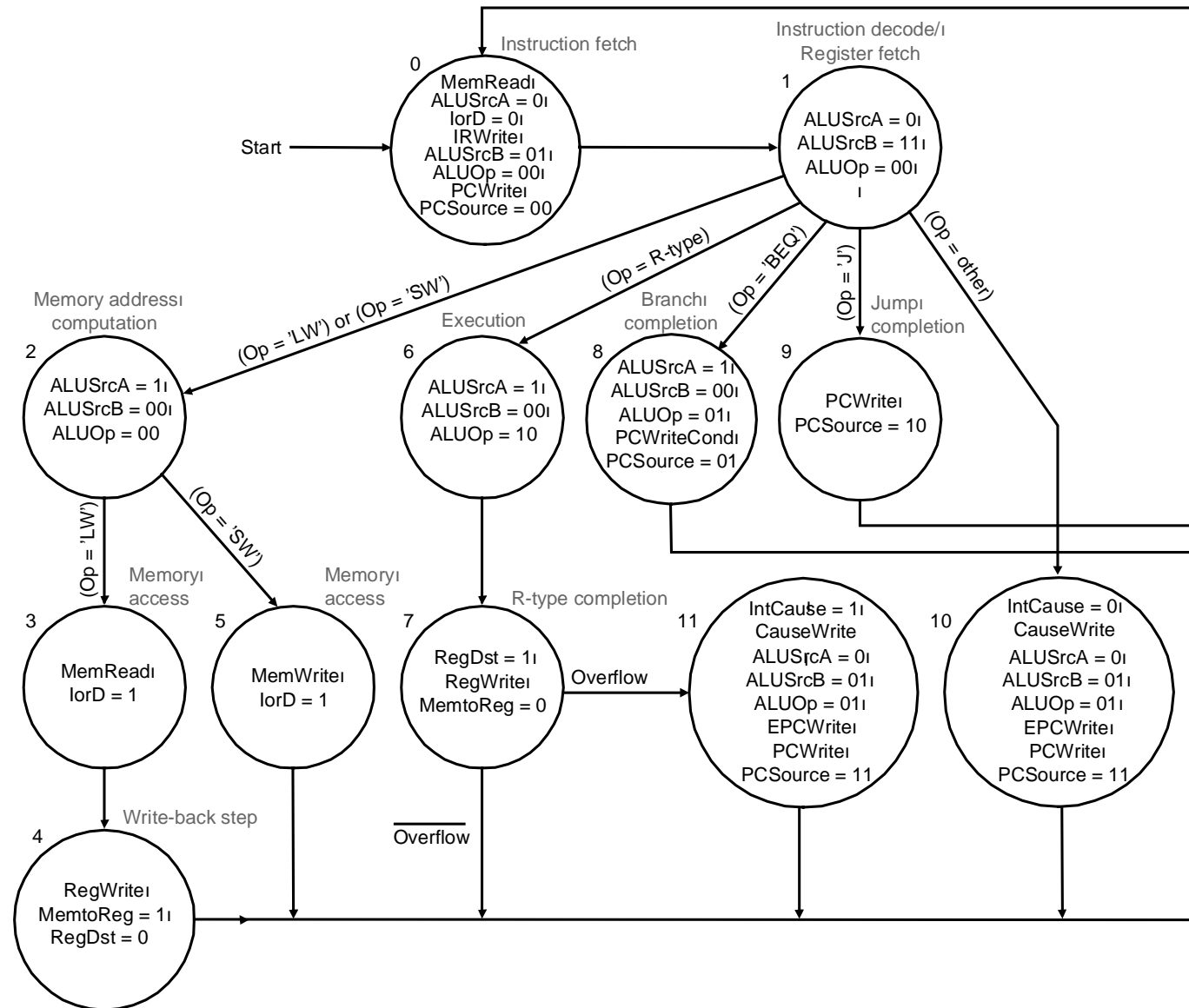

The Big Picture

